



**Worthington
Creyssensac**



**CAST IRON
COMPRESSORS** **PIXAIR®**

From 1 to 10 HP
Tank mounted and base mounted units

... CAST IRON BLOCKS

... SLOW RUNNING

... EASY MAINTENANCE

... SIMPLE AND ROBUST

... RELIABLE

... EXTENDED LIFE

PIXAIR®

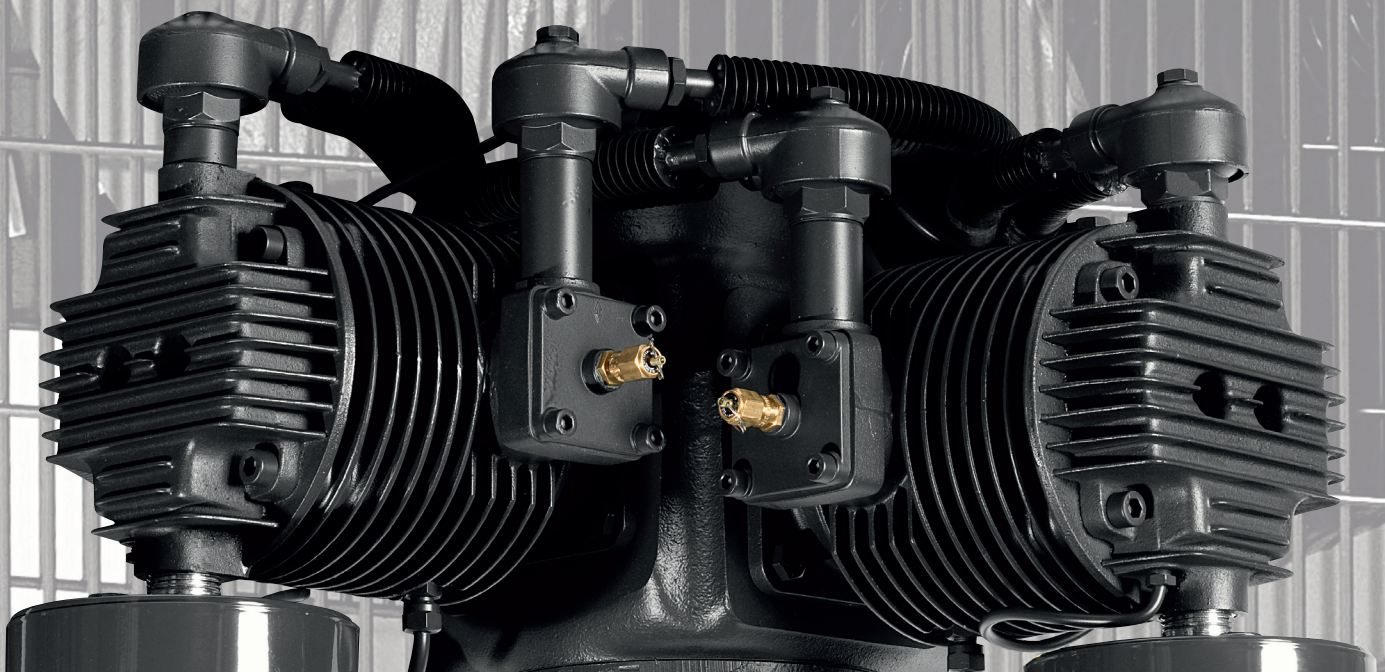

PIXAIR®

WORTHINGTON CREYSSENSAC

CAST IRON COMPRESSORS

With their fully cast iron blocks (crankcase, crankshaft, cylinders, cylinder heads, valve seats), the PIXAIR® compressors are reliable and robust units.

The specific design of the units, with well dimensioned cylinders and efficient cooling, allows the compressor to work at low speed and low temperature (high speed and temperature are the most damaging factors for a piston compressor).

All these advantages make the PIXAIR® a compressor well adapted for intensive use in workshops, automotive market and industrial applications, with exceptional long service life and low noise levels, even when working in hard conditions or dirty atmosphere.

Available in base mounted and tank mounted versions, the PIXAIR® compressors are already equipped with all needed security and regulating components, in order to be connected to your compressed air system and started.

The simple, reliable and robust design of the PIXAIR® compressors will guarantee you long service life and peace of mind.

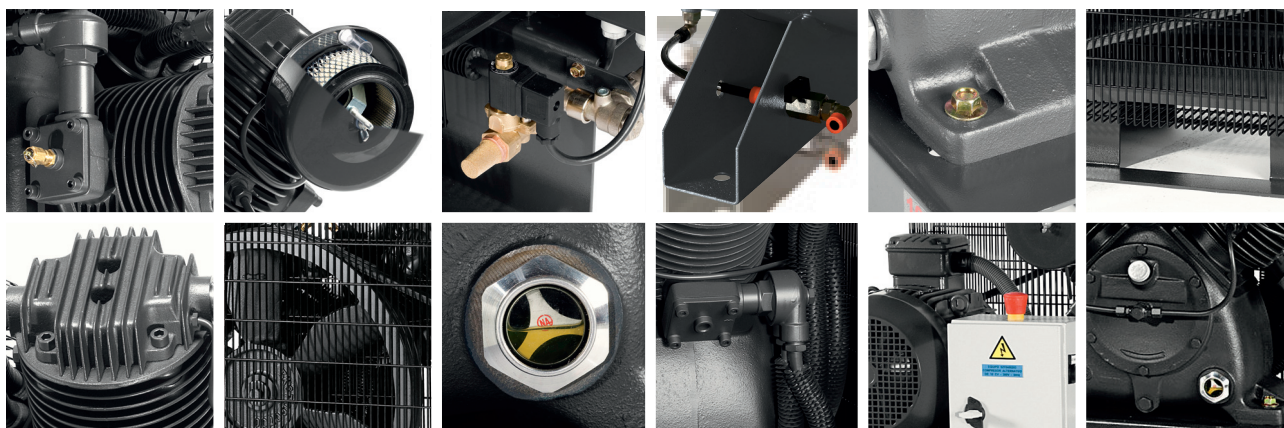

CAST IRON COMPRESSORS PIXAIR®

From 1 to 10 HP
Tank mounted and base mounted units

PIXAIR® range

From 1 to 10 HP

PXR - TANK MOUNTED UNITS



- 1 to 10 HP models.
- 230 or 400V supply according to versions.
- DOL start up to 4 HP.
- DOL or YD start from 5,5 to 10 HP.

Mounted on receiver, tank mounted units are very flexible and can be easily installed and connected to your compressed air system. The air receiver, matched to block size, will ensure an appropriate regulation of the units and constant availability of compressed air.

- 10 and 15 bar versions.
- 60 to 500 litres vessels according to model size.
- Displacement 9,6 to 78 m³/h.

PXR - BASE MOUNTED UNITS



- Modèles 1 à 10 ch.
- Alimentation 230 ou 400 V suivant les versions.
- Démarreur direct jusqu'à 4 ch.
- Démarreur direct ou étoile-triangle de 5,5 à 10 ch.

With their compact design, base mounted units are ready to start and will easily find a place in your workshop. Perfectly adapted if you already have enough air storage capacity in your existing system.

- 10 and 15 bar versions.
- Displacement 9,6 to 78 m³/h.

SXR - SILENCED UNITS



- 2 to 10 HP models.
- 230 or 400V supply according to versions.
- DOL start up to 5,5 HP.
- YD start from 5,5 to 10 HP.

Silenced units are available in base mounted and tank mounted versions, in order to be easily connected to your compressed air system. Thanks to the efficient soundproofing and cooling, the units can be installed close to the working place.

- 10 and 15 bar versions.
- Base frame or 50 to 500 litres vessels according to model size.
- Displacement 16,8 to 78 m³/h.

PIXAIR® compressors

Quality components will guaranty you peace of mind

The PIXAIR® compressors are based on slow running blocks entirely made from cast iron.

Special attention has been paid to detail in order to provide you with a compressor that will run for years:

- **Efficient cooling**
- **Low wear and stress on moving parts**
- **Low maintenance requirement**
- **Low noise level for a piston compressor**

PIXAIR® design is simple and robust, and the fast

The result is a friendly to use compressor, ready to be installed in any system and to produce high quality compressed air.

According to model, compressor blocks can have one or two stages.

Two stage units are based on the differential compression (two cylinders), which allows maximum cooling and high efficiency.

FLYWHEEL

Slow running cast iron flywheel, with large wings. The balance of the flywheel provides high stability to the unit.



AIR FILTERS

Large air filters ensure low pressure drop and high quality air. Maximum accessibility for easy and quick maintenance.



CYLINDERS

Made in cast iron, well dimensioned with large fins for low speed and low temperature running. The internal surface of the cylinders ensures high quality lubrication and reduced wear. Cast iron dimensional stability ensures consistently high performance.



MOTOR, REGULATION

IP55 insulation class F cast iron motors for long life, high efficiency and reliability in hard working conditions. Load/unload regulation carried out through a pressure switch.



DISCHARGE SYSTEM

All units are equipped with a discharge system in order to start without pressure. On 2 stage blocks, a centrifugal system, highly reliable, blows-off air from the cylinders.

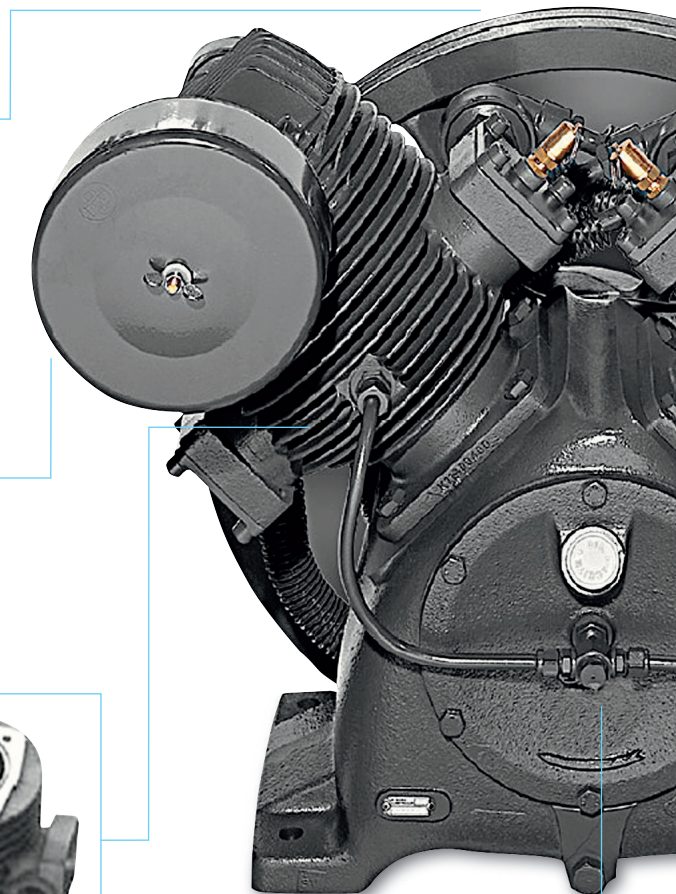

ce of mind, for years

ocus is only on essential parts.

y to be connected to your air
l air.

ve one or two cylinders, with

concept (two stages in a single
high efficiency.

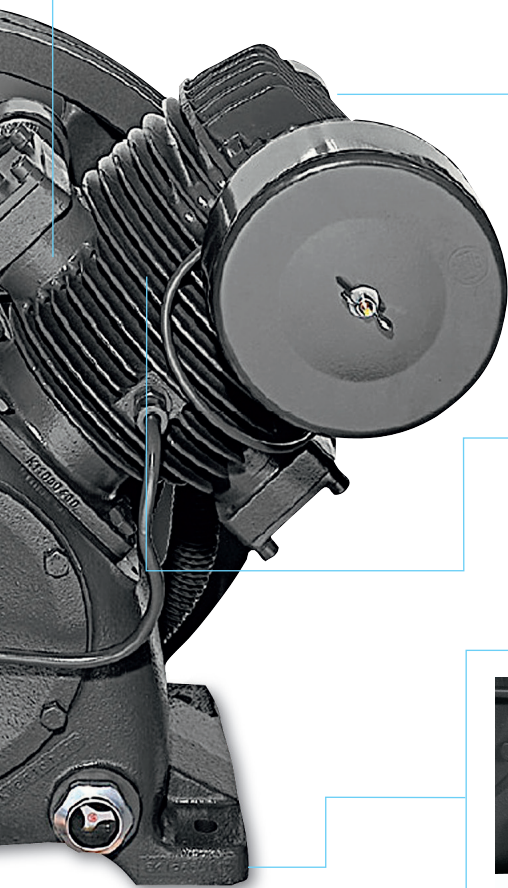

VALVES & PLATE ASSEMBLY

The large valves ensure low pressure drop and reduced absorbed power.



CYLINDER HEADS

Made in cast iron with large fins for efficient cooling.



PISTON, CONNECTING ROD & CRANKSHAFT

Crankshaft made in cast iron. The slow running gives reduced wear, low temperature and long service life.



CRANKCASE

Fully made in cast iron and strongly fixed to the frame, the important inertia gives high stability to the complete unit. Oil sight glass allows easy and quick check of the oil level.



BELT GUARD

Steel belt guard, with service access for maximum user protection.

CAST IRON
COMPRESSORS

PIXAIR®

From 1 to 10 HP
Tank mounted and base mounted units

PIXAIR® - TANK MOUNTED

- Fully cast iron blocks
- Well dimensioned for low speed running (605 to 975 rpm)
- Regulation by pressure switch
- Start-up in vacuum
- IP55 motor insulation class F
- Belt drive with steel guard
- Large cast iron flywheel
- Compact and stable
- Ready to be connected and started
- Low noise level 69 to 78 dB(A)



TECHNICAL DATA - TANK MOUNTED

Description	Power		Supply	Start	Pressure bar	Vessel l	Displ.		Speed RPM	Noise Level dB(A)	Dimensions L - W - H mm	Unit Weight kg	
	hp	kW					l/min	m ³ /h					
1 cylinder/1 stage												10 bar units	
PXR 160A	1	0,75	M/T	DOL	10	60	160	9,6	840	69	1065 - 362 - 730	78	
PXR 2200A	2	1,5	M/T	DOL	10	200	280	16,8	650	72	1445 - 500 - 997	146	
PXR 3200A	3	2,2	M/T	DOL	10	200	380	22,8	870	73	1445 - 500 - 997	147,5	
2 cylinders/1 stage (V type)													
PXR 4300A	4	3	T	DOL	10	300	550	33	605	74	1690 - 520 - 988	193,5	
PXR 5300A	5,5	4	T	DOL/YD	10	300	700	42	840	75	1690 - 533 - 988	206	
PXR 5500A	5,5	4	T	DOL/YD	10	500	700	42	840	75	1971 - 620 - 1100	275,5	
2 cylinders/2 stages (V type)													
PXR 7500A	7,5	5,5	T	DOL/YD	10	500	830	49,8	975	76	1971 - 620 - 1131	301	
PXR 8500A	7,5	5,5	T	DOL/YD	10	500	1050	63	780	75	1971 - 620 - 1220	336,5	
PXR 10500A	10	7,5	T	DOL/YD	10	500	1300	78	965	77	1971 - 620 - 1220	341	
1 cylinder/2 stages												15 bar units	
PXR 3300B	3	2,2	T	DOL	15	300	350	21	800	73	1690 - 520 - 1078	164,5	
PXR 4300B	4	3	T	DOL	15	300	430	25,8	640	74	1690 - 520 - 1098	197	
PXR 5300B	5,5	4	T	DOL	15	300	530	31,8	780	76	1690 - 520 - 1098	204	
2 cylinders/2 stages (V type)													
PXR 6300B	5,5	4	T	DOL/YD	15	300	570	34,2	680	76	1690 - 533 - 1008	228	
PXR 7500B	7,5	5,5	T	DOL/YD	15	450	800	48	695	77	1971 - 620 - 1131	301	
PXR 8500B	7,5	5,5	T	DOL/YD	15	450	935	56,1	700	76	1971 - 620 - 1220	333,5	
PXR 10500B	10	7,5	T	DOL/YD	15	450	1100	66	750	78	1971 - 620 - 1220	340	

Supply: M = 230/1/50 T = 400/3/50
 Start: DOL = Direct On Line YD = Star Delta
 Compressed air outlet connection = ball valve G $\frac{1}{2}$ " F

PIXAIR® - BASE MOUNTED BASE

- Fully cast iron blocks
- Well dimensioned for low speed running (605 to 965 rpm)
- Regulation by pressure switch
- Start-up in vacuum
- IP55 motor insulation class F
- Belt drive with steel guard
- Large cast iron flywheel
- Compact and stable
- Easy to transport with forklift
- Ready to be connected and started
- Low noise level 70 to 78 dB(A)



TECHNICAL DATA - BASE MOUNTED

Description	Power		Supply	Start	Pressure bar	Vessel l	Displ.		Speed RPM	Noise Level dB(A)	Dimensions L - W - H mm	Unit Weight kg
	hp	kW					l/min	m³/h				
1 cylinder/1 stage											10 bar units	
PXR 10A	1	0,75	M/T	DOL	10	-	160	9,6	840	70	675 - 328 - 440	55
PXR 20A	2	1,5	M/T	DOL	10	-	280	16,8	650	73	930 - 441 - 640	112,5
PXR 30A	3	2,2	M/T	DOL	10	-	380	22,8	870	74	930 - 441 - 640	115
2 cylinders/1 stage (V type)												
PXR 40A	4	3	T	DOL	10	-	550	33	605	75	945 - 452 - 570	137,5
PXR 55A	5,5	4	T	DOL/YD	10	-	700	42	840	76	945 - 526 - 570	150
2 cylinders/2 stages (V type)												
PXR 85A	7,5	5,5	T	YD	10	-	1050	63	780	76	1100 - 540 - 685	218,5
PXR 100A	10	7,5	T	YD	10	-	1300	78	965	78	1100 - 540 - 685	223
1 cylinder/2 stages											15 bar units	
PXR 30B	3	2,2	T	DOL	15	-	350	21	800	74	930 - 441 - 660	120,5
PXR 40B	4	3	T	DOL	15	-	430	25,8	640	75	930 - 441 - 675	125
2 cylinders/2 stages (V type)												
PXR 65B	5,5	4	T	DOL/YD	15	-	570	34,2	680	77	965 - 447 - 590	158
PXR 85B	7,5	5,5	T	YD	15	-	935	56,1	700	77	1100 - 540 - 685	218
PXR 100B	10	7,5	T	YD	15	-	1100	66	750	78	1100 - 540 - 685	222

Supply: M = 230/1/50 T = 400/3/50
 Start: DOL = Direct On Line YD = Star Delta
 Compressed air outlet connection = ball valve G $\frac{1}{2}$ " F

PIXAIR SXR - SILENCED

- Silencing hood with perfect cooling of the compressor.
- Very low noise level: possibility to place the unit nearby the workplace.
- Easy access to all components, thanks to removable panels.
- Standard equipment: on/off button, emergency stop, manometer.

- Base mounted or tank mounted (50 to 500L) models - Pressure 10 or 15 bar.
- Base mounted models: must be connected to an air capacity.
- Other specifications: similar to PIXAIR without canopy.)



TECHNICAL DATA - BASE MOUNTED

Description	Power		Supply	Start	Pressure bar	Vessel l	Displ.		Speed RPM	Noise Level dB(A)	Dimensions L - W - H mm	Unit Weight kg
	hp	kW					l/min	m ³ /h				
1 cylinder/1 stage						10 bar units						
SXR 20A	2	1,5	M/T	DOL	10	-	280	16,8	650	64	1045 - 700 - 725	198
SXR 30A	3	2,2	M/T	DOL	10	-	380	22,8	870	65	1045 - 700 - 725	198
SXR 2300A	2	1,5	M/T	DOL	10	300	280	16,8	650	64,5	1635 - 670 - 1250	236
SXR 3300A	3	2,2	M/T	DOL	10	300	380	22,8	870	65	1635 - 670 - 1250	236
2 cylinders/1 stage (V type)												
SXR 250A	2	1,5	M/T	DOL	10	50	310	18,6	900	64	880 - 590 - 840	128
SXR 350A	3	2,2	M/T	DOL	10	50	450	27	1200	64	880 - 590 - 840	128
SXR 40A	4	3	T	DOL	10	-	550	33	605	63	1045 - 700 - 725	217
SXR 55A	5,5	4	T	DOL/YD	10	-	700	42	840	62,3	1045 - 700 - 725	217
SXR 4300A	4	3	T	DOL	10	300	550	33	605	63	1635 - 670 - 1250	269
SXR 5300A	5,5	4	T	DOL/YD	10	300	700	42	840	62,3	1635 - 670 - 1250	269
2 cylinders/2 stages (V type)												
SXR 85A	7,5	5,5	T	YD	10	-	1050	63	780	65,4	1125 - 747 - 775	286
SXR 100A	10	7,5	T	YD	10	-	1300	78	965	67,1	1125 - 747 - 775	286
SXR 8500A	7,5	5,5	T	YD	10	500	1050	63	780	65,4	1975 - 725 - 1400	402
SXR 10500A	10	7,5	T	YD	10	500	1300	78	965	67,1	1975 - 725 - 1400	402
2 cylinders/2 stages (V type)						15 bar units						
SXR 65A	5,5	4	T	DOL/YD	15	-	570	34,2	680	64,5	1045 - 700 - 725	229
SXR 85A	7,5	5,5	T	YD	15	-	935	56,1	700	64	1125 - 747 - 775	286
SXR 100B	10	7,5	T	YD	15	-	1100	66	750	65,7	1125 - 747 - 775	286
SXR 6300B	5,5	4	T	DOL/YD	15	300	570	34,2	680	68	1635 - 670 - 1250	302
SXR 78500B	7,5	5,5	T	YD	15	450	935	56,1	700	64	1975 - 725 - 1400	452
SXR 10500B	10	7,5	T	YD	15	450	1100	66	750	65,7	1975 - 725 - 1400	452

SHARING OUR VALUES

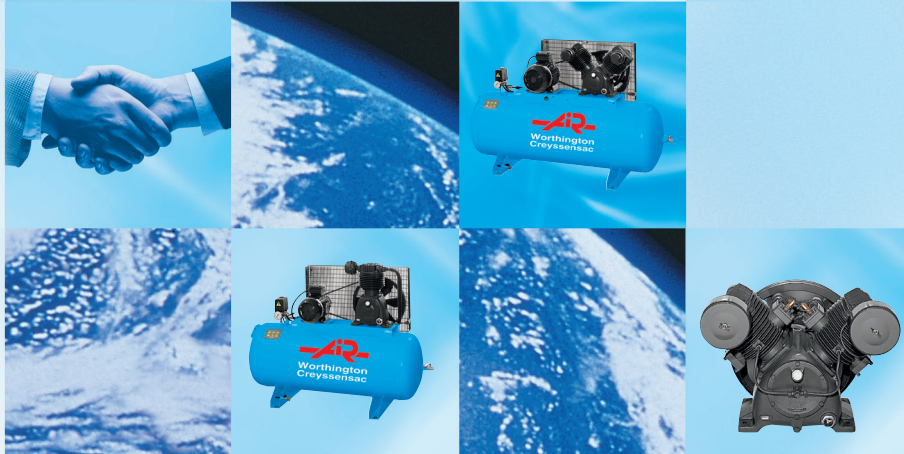

PARTNERSHIPS

Close working partnerships form the foundation of our corporate culture. This identity has grown from our strength in developing long term partnerships with our distribution and sales networks that have local knowledge and experience to provide a total compressed air solution service, tailored specifically to our customers' requirements.

Our business approach has earned us a reputation of trust and loyalty committed to achieving success through partnership.

COMPETENCE

Personnel skill development is a vital part of our success: by a continuous improvement process we improve the ability of our personnel to maintain and improve the service to our customers.

We carry this process through to our partner distributors to ensure that we create a motivated and enthusiastic team working together for the benefit of our customers.

EVOLUTION

Our strategy in product and service development is based on continuous improvement of our products and services in order to meet the requirement of the market and our customers. Continued investment in the design of new products and the use of innovating technologies keep our compressed air solutions amongst the most competitive in the industry. This is our mission to guarantee the satisfaction and trust of our customers.

YOUR DISTRIBUTOR



www.airwco.com